

# 6U VME/VXS — Octal Tiger Sharc Board



**Octal Tiger Sharc Board**

## Design

The CORNET's 6U VME/VXS Octal Tiger SHARC DSP Board (CTI07D04) offers a commercial-off-the-shelf (COTS) digital signal processing solution for system designers. It is ideally suitable for computation demanding field-based signal intelligence (SIGINT) or image intelligence (IMINT) processing applications that requires real-time processing of digitized data.

With two separate buses for computing and communications, the CTI07D04 architecture significantly reduces the bottleneck caused by extensive multitasking and interrupts found in other general-purpose multiprocessing computer architectures.

The computing (Tiger SHARC) bus has eight Analog Devices ADSP-TS201 Tiger SHARC Digital Signal Processors (DSPs). Each DSP runs at a core clock frequency of 500 MHz with a performance of 3.6 GFLOPS for floating-point operations. It has 24 Mbit onchips DRAM. It also has 14 DMA channels for blocked data transfer among the link ports and the bus. 128 MB of SDRAM and 128MB of programmable FLASH are connected in this computing bus.

The DSPs are connected via the 4-bit LVDS link ports, accessible via the VXS/VITA-41 connector on the back plane.

The communication bus (BF561 bus) includes an Analog Devices ADSP-BF561 Blackfin Processor for handling communications among processed data. The Blackfin processor runs at 500 MHz. This bus has 128 MB of SDRAM, 64 MB of programmable FLASH and 1 Mb of SDRAM.

CTI07D04 provides two 10/100/1000Base-T Ethernet ports, a USB 2.0 port, a PMC I/O expansion slot , Two 3mm Audio Jack and VME bus interface for external communication.

## Key Features

- Has eight ADSP-TS201 Tiger SHARC Digital Signal Processors (DSPs)
- Separate buses for computing and communication, thus reducing bottleneck due to multitasking
- Has 14 DMA channels for blocked data transfer among the link ports and the bus
- The Octal TigerSHARC Processor's balanced architecture utilizes characteristics of RISC, VLIW, and DSP to provide a flexible, "all software" approach that adds capacity while reducing costs

## Board Specifications

Processor: Computing: Analog Devices ADSPTS-201 TigerSHARC processor at 500 MHz  
 Communications: Analog Devices AD-SP-561 Blackfin processor at 500 MHz

Memory: Tiger Sharc: Flash: 128 MB  
 SDRAM: 128 MB  
 Blackfin: Flash: 64 MB  
 SDRAM: 128 MB  
 DPRAM: For TS and BF: 18MB  
 For BF and PCI bridge: 18MB

Front Panel I/O : Two 10/100/1000Base-T Ethernet ports  
 One DB-9 RS-232 serial port  
 One USB 2.0 port  
 Two 3mm stereo audio jacks  
 One PMC site

Real Panel I/O: P2: One 10/100/1000Base-T Host Ethernet  
 Two Stereo audio output  
 One PMC site (per VITA-35)  
 One USB 2.0  
 One UART

VXS P0: 8x Link Ports at up to 1 GB/sec data rate, implemented using VITA 41.1 Infiniband LVDS standard

Bus: PCI  
 VME 64X  
 Processor local bus

Bridges: PCI bridge uses PLX9056  
 VME bridge uses TSI148

Sensor: Three temperature sensors used

## Mechanical

Form factor: 6U VME, 4TE  
 Dimensions: 233.4 mm x 160 mm x 20 mm

## Power

Supply: +5V and +3.3V from VME back-plane  
 Consumption: 40W max

## Environment

Cooling: Convection Air Cooling  
 Operating Temp: -20°C to 55°C  
 Storage Temp: -40°C to 85°C  
 Humidity: Humidity: 10-90% at room temperature non-condensing

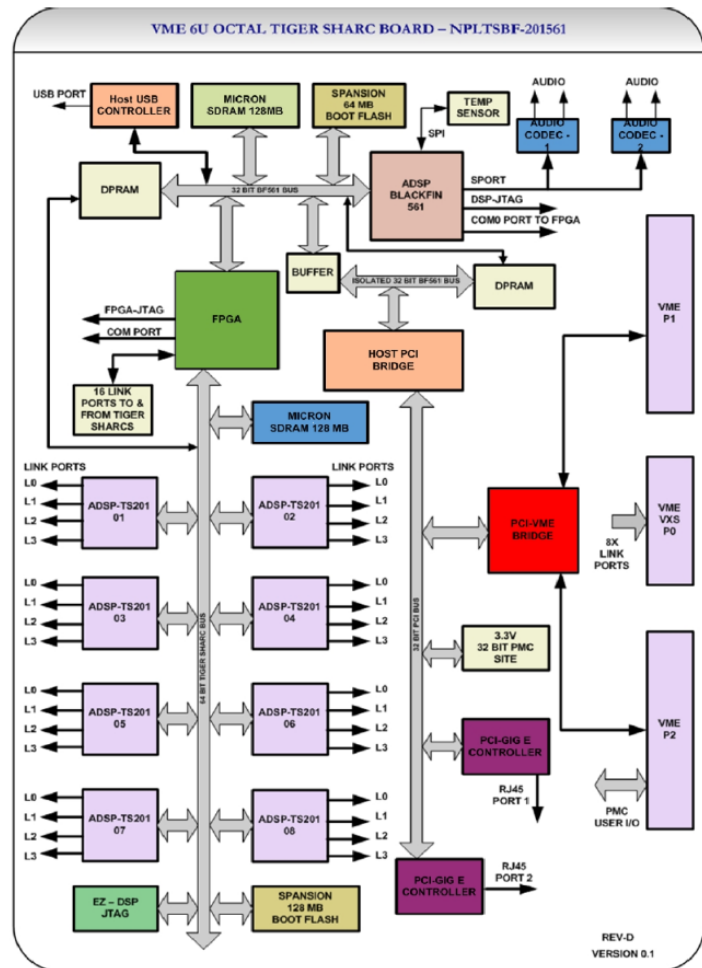

Block Diagram



ISO-9001:2015 Registered

Cornet Technology, Inc. • 6800 Versar Center, Springfield, VA 22151  
 703.658.3400 • 703.658.3440 fax • www.cornet.com

© 2014 Cornet Technology, Inc. All rights reserved.  
 In the interest of continuous improvement, Cornet Technology, Inc. reserves the right to change specifications without prior notice.

Product is Subject to U.S. Export Laws